

**1-3" Top Mount Systems**

**Field Assembly Guide  
to Prep, Position, & Fill**



# Table of Contents

## **Pre-Installation**

Inspection for Damage. . . . .	3
Operating Pressure and Temperature. . . . .	3
Parts Breakdown. . . . .	3

<b>Preparing and Positioning</b> . . . . .	5
--	---

<b>Filling</b> . . . . .	6
--------------------------	---

<b>Gravel and Media Quantity Sheet</b> . . . . .	7
--	---

# Pre-Installation

## IMPORTANT

### Prior to Beginning Assembly and Filling:

Inspect all components and tanks for damage during shipping. Reference the parts breakdown images for your distribution system on pages 3 and 4 and check off the components below to confirm they are present. Reference the gravel and media quantities on page 7 and confirm the correct type and quantity is present.

- |   |   |  |   |
|---|---|--|---|
| <input type="checkbox"/> Lateral Hub      | <input type="checkbox"/> Laterals (x8)        | <input type="checkbox"/> Black Threaded Top Flange | <input type="checkbox"/> Flange Bolt Kit (CH4750) |
| <input type="checkbox"/> Distributor Tube | <input type="checkbox"/> Chrome QC Top Flange | <input type="checkbox"/> Black Bottom Tank Plate   |   |

Thoroughly review the instructions within this guide to understand and become familiar with the placement, field assembly, and media loading process of a top mount system.

**All commercial top mount systems require assembly and filling in the field.**

**Failure to understand and comply with the instructions within this guide may result in failure of the unit, causing significant damage to the unit and its surroundings.**

## Operating Pressure and Temperature

The normal operating pressure is 30 – 85 psi.

- If the incoming water pressure is higher than 85 psi, a regulating valve must be installed.
- If the incoming water pressure is lower than 30 psi, a regulated booster pump must be installed.

The normal operating temperature is 40 – 100° Fahrenheit.

## Parts Breakdown

For 1" – 2" valve systems:

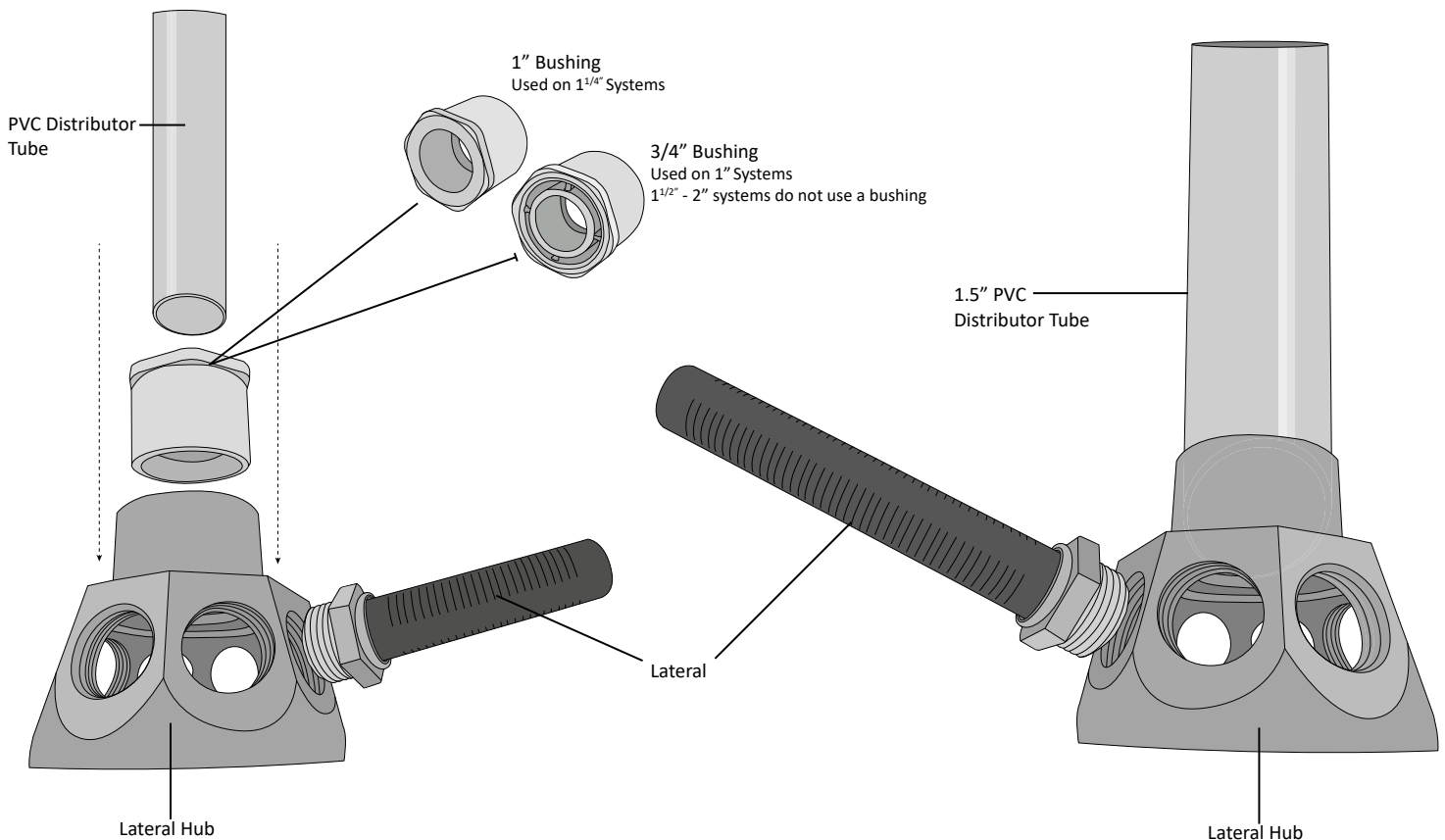

# Pre-Installation

## Parts Breakdown

For 3" valve systems or tanks larger than 24" in diameter:

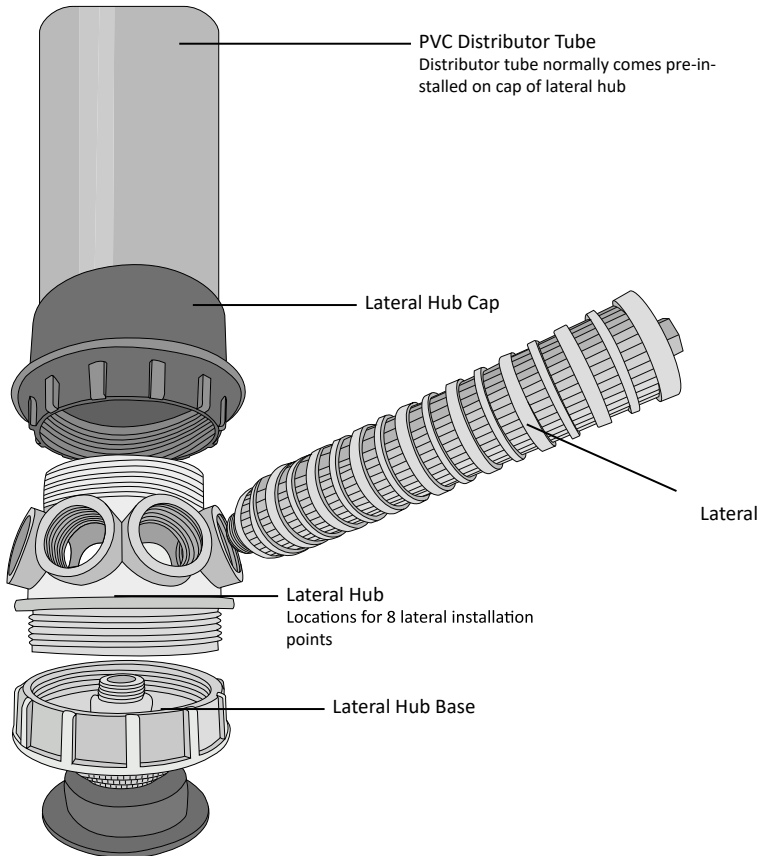

## Top and Bottom Flanges

It is critical to ensure that flanges are installed and the plate bolts are tightened adequately prior to filling. Failure will lead to critical leak issues which may require emptying media to re-install.

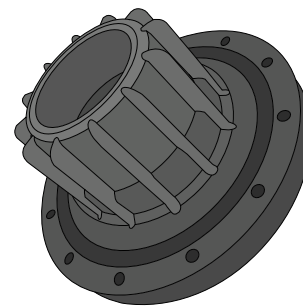
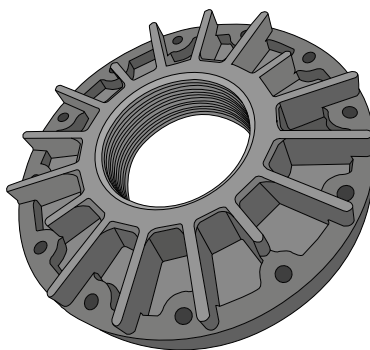
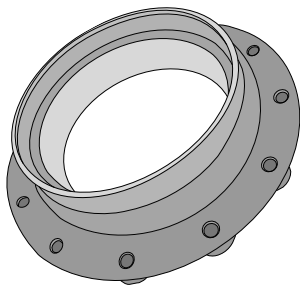

## Flange Bolt Kit

Flange bolts are installed in the order shown below:

1. Flange Bolt →
2. Flat Washer →
3. Flange/Plate →
4. Flat Washer →
5. Lock Washer →
6. Flange Nut



# Preparing & Positioning

## Preparing and Positioning the Unit

1. Select a position near a drain that has adequate carrying capacity to handle the unit's backwash flow rate. Refer to the system's specification sheet for the backwash flow rate.
2. Follow the Distribution Installation instructions in the illustrations below before proceeding to step 3.

### Top Mount Distribution Installation Instructions:

**A.** Carefully place mineral tank on its side. With the distributor hub inside the tank, screw the lateral clockwise into one of the eight hub slots. Continue threading laterals into hubs until **hand tight**. Repeat process until all eight laterals are installed.

**Do not over-tighten or use thread compound on laterals.**

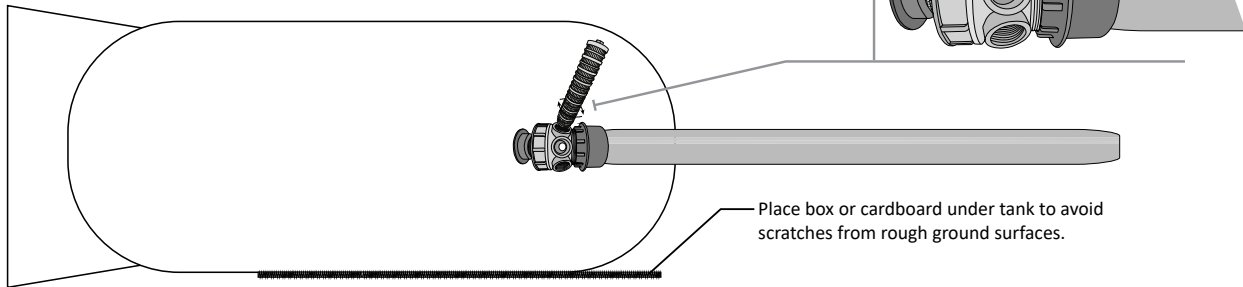

**B.** Slide the distribution system into the tank slowly to avoid shock. Continue until the hub rests against the bottom of the tank.

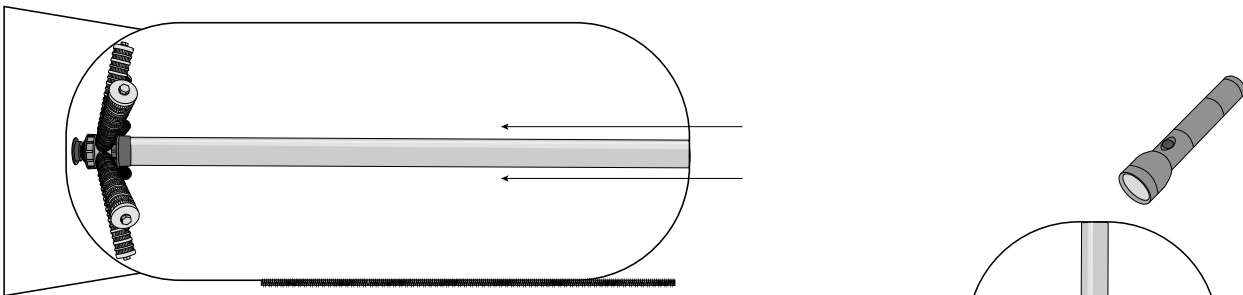

**C.** Slowly raise the unit upright near the final installation location. Using a flashlight, re-inspect the distribution hub and laterals for potential damage incurred from raising the tank.

The distribution system is now installed. Continue with step 3 on the following page.

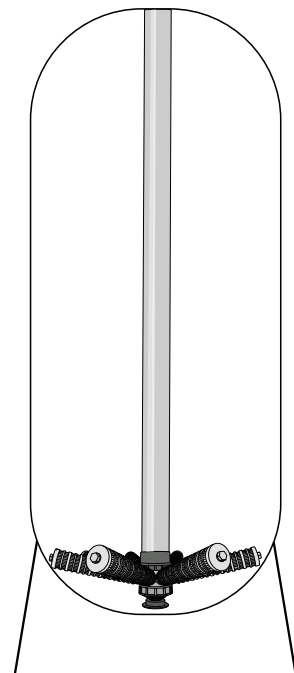

# Positioning & Filling

## Preparing and Positioning the Unit (continued)

- Place the tank on a level and firm foundation (preferably concrete). Verify that the riser tube is flush with the top of the tank.  
**Tip:** It is recommended to spin the control valve on the tank to verify that the valve and tank orientation are correct.
- Determine and mark the location of the brine maker (for softeners only). It is not necessary to place it in this location yet.
- For installers: Check, Initial, and Date the following boxes prior to proceeding to the filling instructions.

Before continuing, I have ensured that:	Initials	Date
<input type="checkbox"/> The distribution system has been successfully installed and inspected for damage.		
<input type="checkbox"/> The unit is located in its final position. <b>*It is not recommended to reposition tanks after filling!</b>		
<input type="checkbox"/> The plumbing layout is correct.		

## Filling Instructions

**Note: DO NOT proceed with filling instructions until unit is in its final position.**

- If installed, remove the valve from the top of the tank.
- Verify that the riser tube is flush with the top of the tank. Re-inspect the distribution system with a flashlight and confirm the components are still in place and undamaged.
- Cover the opening of the distributor tube with the provided rubber cap. This prevents gravel or media from entering the distributor assembly during the filling process.
- Verify that the correct type and amount of gravel for the unit being installed is present. The correct type and amount can be confirmed on the table on page 7.

**NOTE: If the correct type and amount of gravel is not on site, do not load the tank.  
Contact the distributor or factory for corrections.**

**TIP: On tanks 24" and larger, fill tank 1/4 full with water to aid in gravel filling.**

- Prepare to add mineral to the tank. Verify that the correct type and amount of mineral for the softener or filter that is being installed is on site. The correct type and amount can be confirmed on the table on page 6.

**NOTE: If the correct type and amount of mineral is not on site, do not load the tank.  
Contact the distributor or factory for corrections.**

- Slowly pour in the correct amount of mineral.
- If possible, fill the tank to the top with water at this time.
- Remove the rubber cover from the top of the riser pipe. Clean the riser pipe, tank threads and the exterior of the tank of any excess media or gravel debris.
- Lubricate the distributor O-ring seal and tank ring seal using a non-aerosol, food grade silicone lubricant.
- Align the riser pipe into the control valve, taking care to seat the riser pipe against the internal O-ring. With the distributor tube in place, push the control valve down until it pushes against the tank threads.
- Turn the control valve clockwise, taking caution to not cross-thread, until the gasket seats and is tight.
- Verify that the orientation of the control valve is correct before installing the plumbing.

# Gravel & Media Quantity

## Amount and Type of Media:

Gravel Type and Quantity	
Add _____ lbs. of _____	Gravel Underbedding
Add _____ lbs. of _____	Gravel Underbedding

Media Type and Quantity	
Add _____ Cu. Ft. of _____	Media
Add _____ Cu. Ft. of _____	Media
Add _____ Cu. Ft. of _____	Media
Add _____ Cu. Ft. of _____	Media

## Inspection Sign-off (Please Initial):

Factory Inspection: _____
Initials From Assembly Team Leader: _____

**Note: The instructions and illustrations in this guide are only intended to be used as general guidelines for assembling a Commercial Top Mount System in the field. Units and assemblies will differ from those detailed in this guide. Contact the manufacturer for more information.**



1900 Prospect Court • Appleton, WI 54914  
Phone: 920-739-9401 • Fax: 920-739-9406

